

RFID MODULE

Mifare Reader / Writer

SL030

User Manual

Version 3.0

January 14, 2016

StrongLink

CONTENT

1. MAIN FEATURES.....	3
2. PINNING INFORMATION.....	4
3. Device Operation.....	5
3-1. CLOCK AND DATA TRANSITIONS:.....	5
3-2. START CONDITION.....	5
3-3. STOP CONDITION.....	5
3-4. ACKNOWLEDGE.....	5
3-5. BUSY STATE.....	6
3-6. DEVICE ADDRESSING.....	6
3-7. WRITE OPERATIONS.....	7
3-8. READ OPERATIONS.....	7
4. COMMAND DESCRIPTION.....	7
4-1. FORMAT.....	7
4-2. Command Overview.....	8
4-3. COMMAND LIST.....	9
4-3-1. SELECT MIFARE CARD.....	9
4-3-2. LOGIN TO A SECTOR.....	9
4-3-3. DOWNLOAD KEY INTO SL030.....	9
4-3-4. LOGIN SECTOR VIA STORED KEY.....	11
4-3-5. READ A DATA BLOCK.....	11
4-3-6. WRITE A DATA BLOCK.....	11
4-3-7. READ A VALUE BLOCK.....	11
4-3-8. INITIALIZE A VALUE BLOCK.....	12
4-3-9. WRITE MASTER KEY (KEYA).....	12
4-3-10. INCREMENT VALUE.....	12
4-3-11. DECREMENT VALUE.....	13
4-3-12. COPY VALUE.....	13
4-3-13. READ A DATA PAGE (ULTRALIGHT & NTAG203).....	14
4-3-14. WRITE A DATA PAGE (ULTRALIGHT & NTAG203).....	14
4-3-15. REQUEST FOR ANSWER TO SELECT (ISO14443-4).....	14
4-3-16. EXCHANGE TRANSPARENT DATA (T = CL).....	14
4-3-17. LED CONTROL.....	14
4-3-18. POWER DOWN.....	15
4-3-19. WRITE PERSO.....	15
4-3-20. COMMIT PERSO.....	15
4-3-21. GET FIRMWARE VERSION.....	16
4-3-22. TURN ON/OFF AUTO-DETECTION.....	16
5. DIFFERENCES FROM PREVIOUS VERSION.....	16

1. MAIN FEATURES



*This picture may not be exactly the same as real object.

- Tags supported: Mifare 1k, Mifare 4k, Mifare UltraLight, Mifare UltraLight C, NTAG203, DESFire, DESFire EV1 and Mifare Plus 2K/4K
- Built-in antenna
- 0 to 400 KHz bit-wide I²C-bus communication
- 2.7 ~ 3.6V VDC operating, I/O pins are 5V tolerant
- Work current less than 45mA @3.3V
- Power down current less than 10uA
- Operating distance: Up to 50mm, depending on tag
- Storage temperature: -40 °C ~ +85 °C
- Operating temperature: -25 °C ~ +55 °C
- Dimension: 38 × 38 × 3 mm
- The OUT pin at low level indicates tag in detective range, and high level indicating tag out
- Auto-detection: LED is on when card is in the detection range¹

¹ Supports all cards above except ISO14443-4 cards like DESFire/DESFire EV1 and MifarePlus L0/L2/L3. There is Auto-detection command to control its on/off.

2. PINNING INFORMATION

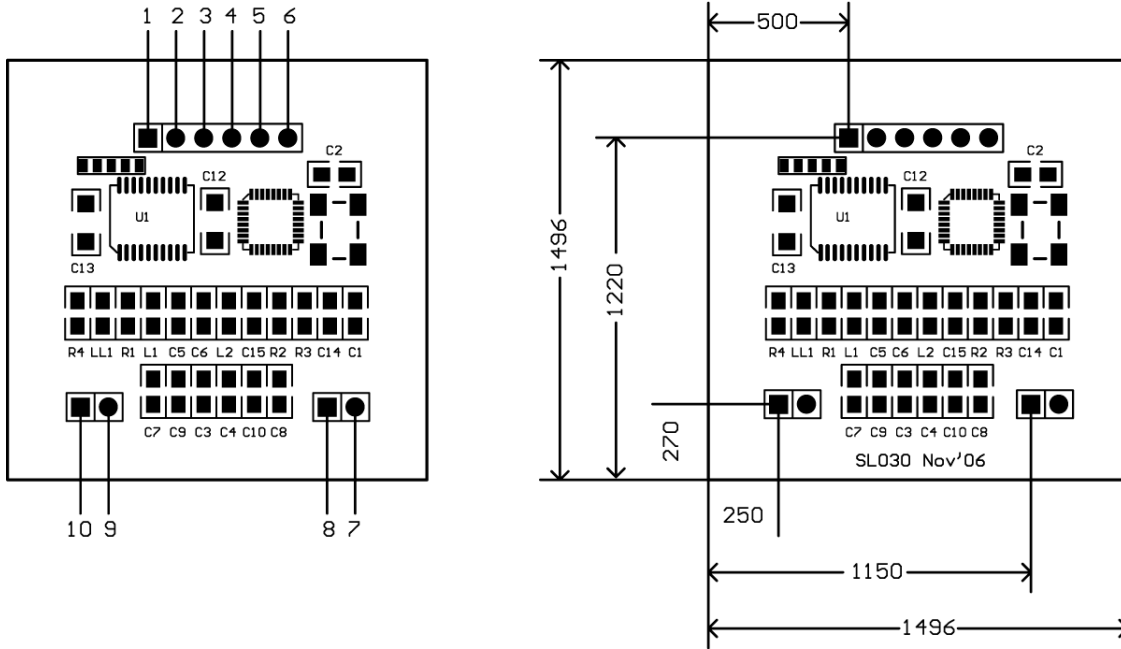

Unit: mil
 100 mil between two pads

PIN	SYMBOL	TYPE	DESCRIPTION
1	VDD	PWR	Power supply, 2.7V to 3.6VDC
2	IN	Input	Falling edge wake up SL030 from power down mode
3	SDA	Input/Output	Serial Data Line
4	SLC	Input	Serial Clock Line
5	Out	Output	Tag auto-detection signal low level indicating tag in high level indicating tag out
6	GND	PWR	Ground
7	NC		
8	NC		
9	NC		
10	NC		

Attention: Pin IN must be connected HIGH voltage when working, so SL030 can enter power down mode properly.

3. Device Operation

3-1. Clock and Data Transitions:

The SDA pin is normally pulled high with an external device. Data on the SDA pin may change only during SCL low time periods. Data changes during SCL high periods will indicate a start or stop condition as defined below.

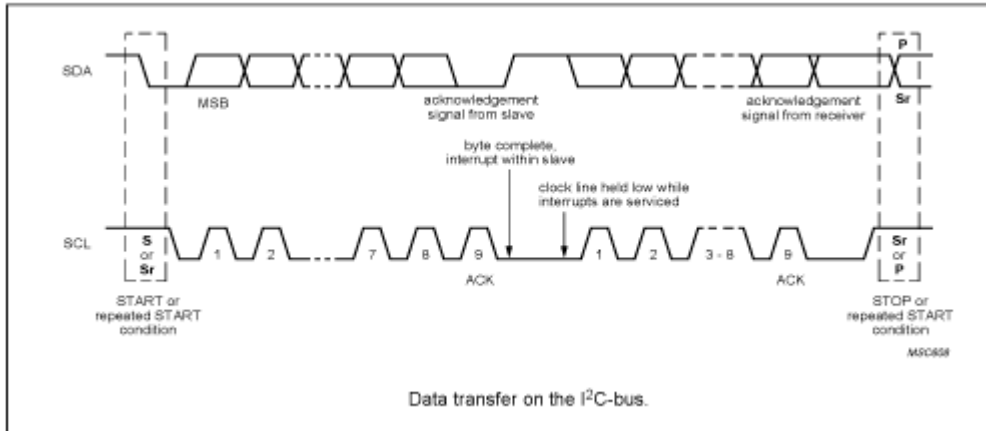

3-2. Start Condition

A high-to-low transition of SDA with SCL high is a start condition which must precede any other command

3-3. Stop Condition

A low-to-high transition of SDA with SCL high is a stop condition.

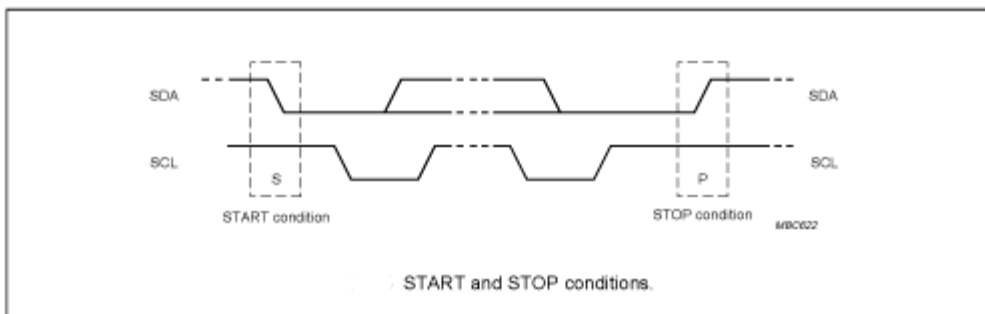

3-4. Acknowledge

All addresses and data words are serially transmitted to and from the SL030 in 8-bit words. The SL030 sends a zero to acknowledge that it is not busy, and has received each word. This happens during the ninth clock cycle.

3-5. Busy State

When the SL030 has received command, then don't acknowledge IIC bus until ends with the card communication.

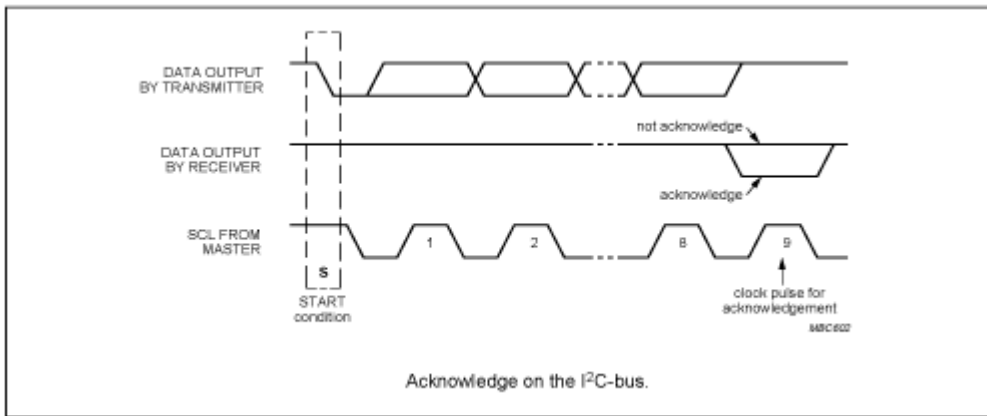

3-6. Device Addressing

The SL030 devices require an 8-bit device address word following a start condition to enable the chip for a read or write operation.

The device address word consists of 7 bits addressing and 1 bit operation select bit.

The first 7 bits are the SL030 addressing, is 10100xx depend on JP1 and JP2 status as below table

	JP1	JP2	Address
shorted	no	no	1010000 (default)
	no	yes	1010001
	yes	no	1010010
	yes	yes	1010011

The eighth bit of the device address is the read/write operation select bit. A read operation is initiated if this bit is high and a write operation is initiated if this bit is low.



The first byte after the START procedure.

3-7. Write Operations

The host device send a command(refer chapter 4) to SL030 via write operation, then SL030 will carry out the order that receive. Finished time according to different order

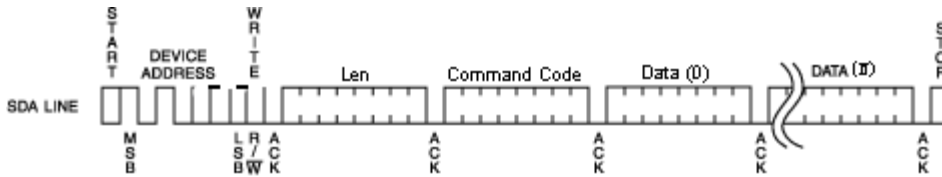

3-8. Read Operations

The host device passes to read the operation gets the order carries out the result

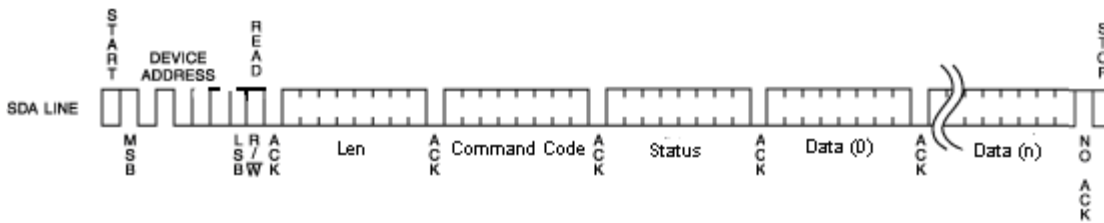

4. COMMAND DESCRIPTION

4-1. FORMAT

Host Write Command to SL030:

Address	Len	Command	Data
---------	-----	---------	------

- Address: 1 byte, 0xA0
- Len: 1 byte indicating the number of bytes from Command to the end of Data
- Command: 1 byte Command code, see Table 3
- Data: Variable length depends on the command type

Host Read The Result:

Address	Len	Command	Status	Data
---------	-----	---------	--------	------

- Address: 1 byte, 0xA1
- Len: 1 byte indicating the number of bytes from Command to the end of Data
- Command: 1 byte Command code, see Table 3
- Status: 1 byte Command status, see Table 4
- Data: Variable length depends on the command type.

4-2. Command Overview

Table 3

Command	Description
0x01	Select Mifare card
0x02	Login to a sector
0x03	Read a data block
0x04	Write a data block
0x05	Read a value block
0x06	Initialize a value block
0x07	Write master key (key A)
0x08	Increment value
0x09	Decrement value
0x0A	Copy value
0x10	Read a data page (Ultralight & NATG203)
0x11	Write a data page (Ultralight & NTAG203)
0x12	Download Key
0x13	Login sector via stored Key
0x20	Request for Answer to Select (ISO14443-4)
0x21	Exchange Transparent Data according to T = CL
0x40	LED control
0x50	Go to Power Down mode
0x80	MFP WritePerso
0x81	MFP CommitPerso
0xF0	Get firmware version
0xFE	Turn on/off Auto-detection

STATUS OVERVIEW**Table 4**

Status	Description
0x00	Operation succeed
0x01	No tag
0x02	Login succeed
0x03	Login fail
0x04	Read fail
0x05	Write fail
0x06	Unable to read after write
0x08	Address overflow
0x09	Download Key fail
0x0A	Collision occur
0x0C	Load key fail
0x0D	Not authenticate
0x0E	Not a value block
0x0F	Input len invalid
0x12	MFP WritePerso fail
0x13	MFP CommitPerso fail
0xF1	Invalid command

4-3. COMMAND LIST

4-3-1. Select Mifare card

Host Write:

Len	0x01
-----	------

Host Read:

Len	0x01	Status	UID	Type
-----	------	--------	-----	------

Status: 0x00: Operation succeed

0x01: No tag

UID: The uniquely serial number of Mifare card

Type:

MFMini_4B	0x01
MFMini_7B	0x02
MF1K_4B UID/ MFPLUS2K SL1_4B UID	0x03
MF1K_7B UID/ MFPLUS2K SL1_7B UID	0x04
MF4K_4B UID/ MFPLUS4K SL1_4B UID	0x05
MF4K_7B UID/ MFPLUS4K SL1_7B UID	0x06
MF Ultralight/MF Ultralight C/Ntag 203	0x07
MF DESFire/MF DESFire EV1	0x09
MF PROX	0x0B
MFPLUS2K SL2_4B UID	0x21
MFPLUS4K SL2_4B UID	0x22
MFPLUS2K SL2_7B UID	0x23
MFPLUS4K SL2_7B UID	0x24
MFPLUS2K SL0/SL3_4B UID ²	0x31
MFPLUS4K SL0/SL3_4B UID	0x32
MFPLUS2K SL0/SL3_7B UID	0x33
MFPLUS4K SL0/SL3_7B UID	0x34
Other	0x00

4-3-2. Login to a sector

Host Write:

Len	0x02	Sector	Type	Key
-----	------	--------	------	-----

Sector: Sector need to login, 0x00 – 0x27

Type: Key type (0xAA: authenticate with KeyA, 0xBB: authenticate with KeyB)

Key: Authenticate key, 6 bytes

Host Read:

Len	0x02	Status
-----	------	--------

Status: 0x02: Login succeed

0x01: No tag

0x03: Login fail

0x08: Address overflow

4-3-3. Download Key into SL030

² Mifare Plus SL0 and SL3 can tell differences via ATS(ISO14443-4). Before ATS, they have the same ATQA and SAK(ISO14443-3). SL030 judges card type only via ISO14443-3 layer for the compatibility.

Host Write:

Len	0x12	Sector	Type	Key
-----	------	--------	------	-----

Sector: 0x00 – 0x27

Type: Key type (0xAA: KeyA, 0xBB: KeyB)

Key: 6 bytes, stored into SL030

Host Read:

Len	0x12	Status
-----	------	--------

Status: 0x00: Operation succeed

0x08: Address overflow

0x09: Download fail

Note: Some delay is needed between Host Write and Host Read.

4-3-4. Login sector via stored key**Host Write:**

Len	0x13	Sector	Type
-----	------	--------	------

Sector: Sector need to login, 0x00 – 0x27

Type: Key type (0xAA: KeyA, 0xBB: KeyB)

Host Read:

Len	0x13	Status
-----	------	--------

Status: 0x02: Login succeed

0x03: Login fail

0x08: Address overflow

4-3-5. Read a data block**Host Write:**

Len	0x03	Block
-----	------	-------

Block: The absolute address of block to be read, 1 byte

Host Read:

Len	0x03	Status	Data
-----	------	--------	------

Status: 0x00: Operation succeed

0x01: No tag

0x04: Read fail

0x0D: Not authenticate

Data: Block data returned if operation succeeds, 16 bytes.

4-3-6. Write a data block**Host Write:**

Len	0x04	Block	Data
-----	------	-------	------

Block: The absolute address of block to be written, 1 byte.

Data: The data to write, 16 bytes.

Host Read:

Len	0x04	Status	Data
-----	------	--------	------

Status: 0x00: Operation succeed

0x01: No tag

0x05: Write fail

0x06: Unable to read after write

0x0D: Not authenticate

Data: Block data written if operation succeeds, 16 bytes.

4-3-7. Read a value block**Host Write:**

Len	0x05	Block
-----	------	-------

Block: The absolute address of block to be read, 1 byte.

Host Read:

Len	0x05	Status	Value
-----	------	--------	-------

Status: 0x00: Operation succeed
 0x01: No tag
 0x04: Read fail
 0x0D: Not authenticate
 0x0E: Not a value block
 Value: Value returned if the operation succeeds, 4 bytes.

4-3-8. Initialize a value block

Host Write:

Len	0x06	Block	Value
-----	------	-------	-------

Block: The absolute address of block to be initialized, 1 byte.
 Value: The value to be written, 4 bytes.

Host Read:

Len	0x06	Status	Value
-----	------	--------	-------

Status: 0x00: Operation succeed
 0x01: No tag
 0x05: Write fail
 0x06: Unable to read after write
 0x0D: Not authenticate
 Value: Value written if the operation succeeds, 4 bytes.

4-3-9. Write master key (KeyA)

Host Write:

Len	0x07	Sector	Key
-----	------	--------	-----

Sector: The sector number to be written, 0x00 – 0x27.
 Key: Authentication key, 6 bytes

Host Read:

Len	0x07	Status	Key
-----	------	--------	-----

Status: 0x00: Operation succeed
 0x01: No tag
 0x05: Write fail
 0x08: Address overflow
 0x0D: Not authenticate
 Key: Authentication key written if the operation succeeds, 6 bytes.
 Attention: Be sure KeyB is readable, otherwise KeyB will be change to 000000000000 after this command.

4-3-10. Increment value

Host Write:

Len	0x08	Block	Value
-----	------	-------	-------

Block: The absolute address of block to be increased, 1 byte.
 Value: The value to be increased by, 4 bytes.

Host Read:

Len	0x08	Status	Value
-----	------	--------	-------

Status: 0x00: Operation succeed
 0x01: No tag
 0x05: Write fail
 0x06: Unable to read after write
 0x0D: Not authenticate
 0x0E: Not a value block

Value: The value after increment if the operation succeeds, 4 bytes

4-3-11. Decrement value

Host Write:

Len	0x09	Block	Value
-----	------	-------	-------

Block: The absolute address of block to be decreased, 1 byte

Value: The value to be decreased by, 4 bytes

Host Read:

Len	0x09	Status	Value
-----	------	--------	-------

Status: 0x00: Operation succeed
 0x01: No tag
 0x05: Write fail
 0x06: Unable to read after write
 0x0D: Not authenticate
 0x0E: Not a value block

Value: The value after decrement if the operation succeeds, 4 bytes

4-3-12. Copy value

Host Write:

Len	0x0A	Source	Destination
-----	------	--------	-------------

Source: The source block copy from, 1 byte

Destination: The destination copy to, 1 byte

The source and destination must in the same sector

Host Read:

Len	0x0A	Status	Value
-----	------	--------	-------

Status: 0x00: Operation succeed
 0x01: No tag
 0x05: Write fail
 0x06: Unable to read after write
 0x0D: Not authenticate
 0x0E: Not a value block (Source)

Value: The value after copy if the operation succeeds, 4 bytes

4-3-13. Read a data page (UltraLight & NTAG203)**Host Write:**

Len	0x10	Page
-----	------	------

Page: The page number to be read, 1 byte

Host Read:

Len	0x10	Status	Data
-----	------	--------	------

Status: 0x00: Operation succeed

0x01: No tag

0x04: Read fail

0x08: Address overflow

Data: Block data returned if operation succeeds, 4 bytes.

4-3-14. Write a data Page (UltraLight & NTAG203)**Host Write:**

Len	0x11	Page	Data
-----	------	------	------

Page: The page number to be written, 1 byte.

Data: The data to write, 4 bytes.

Host Read:

Len	0x11	Status	Data
-----	------	--------	------

Status: 0x00: Operation succeed

0x01: No tag

0x05: Write fail

0x06: Unable to read after write

0x08: Address overflow

Data: page data written if operation succeeds, 4 bytes.

4-3-15. Request for Answer to Select (ISO14443-4)

Len	0x20
-----	------

Response:

Len	0x20	Status	ATS
-----	------	--------	-----

Status: 0x00: Operation succeed

0x10: Address overflow

ATS: According to ISO14443-4 protocol

$Len + T_0 + TA_1 + TB_1 + TC_1 + A_1 + A_K$

4-3-16. Exchange Transparent Data (T = CL)

Len	0x21	Data
-----	------	------

Data: COS command

Response:

Len	0x21	Status	Data
-----	------	--------	------

Status: 0x00: Operation succeed

0x11: Communicate with card failed

Data: Response data from card

4-3-17. LED Control

Host Write:

Len	0x40	Data
-----	------	------

Data: 0x00: LED off
0x01: LED on

Host Read:

Len	0x40	Status
-----	------	--------

Status: 0x00: Operation succeed

4-3-18. Power Down**Host Write:**

Len	0x50
-----	------

Host Read:

Len	0x50	Status
-----	------	--------

Status: 0x00: Operation succeed

Note: Some delay is needed when waking up SL030.

4-3-19. Write Perso**Host Write:**

Len	0x80	Bnr	Data
-----	------	-----	------

Bnr: 2Byte Block or Key Address to be written, MSB first.

For example,

Master Key Address is 0x9000, and write it as 0xFFFF..FF(16Bytes)

13809000FFFFFFFFFFFFFFFFFFFFFFFFFFFFFFFFh

Configuration Key Address is 0x9001, and write it as 0xFFFF..FF(16Bytes)

13809001FFFFFFFFFFFFFFFFFFFFFFFFFFFFFFFFh

Switch to Level 2 Key Address is 0x9002, and write it as 0xFFFF..FF(16Bytes)

13809002FFFFFFFFFFFFFFFFFFFFFFFFFFFFFFFFh

Switch to Level 3 Key Address is 0x9003, and write it as 0xFFFF..FF(16Bytes)

13809003FFFFFFFFFFFFFFFFFFFFFFFFFFFFFFFFh

Data: Value of the key or data

Host Read:

Len	0x80	Status
-----	------	--------

Status: 0x00: Operation succeed

0x11: Communicate with card failed

0x12: Card Write Perso failed

4-3-20. Commit Perso**Host Write:**

Len	0x81
-----	------

This command commit the Write Perso and switch the card to security level 1(SL1 card) or level 3(SL3 card).

Host Read:

Len	0x81	Status
-----	------	--------

Status: 0x00: Operation succeed

0x11: Communicate with card failed

0x13: Card Commit Perso failed

Attention: According to NXP MifarePlus card document, Commit Perso will make effect after you have “Write Perso” the Master KEY, Configuration KEY and SWL3 KEY.

If your card is L1 card, after Commit Perso, the card will switch L0 to L1;

If your card is L3 card, after Commit Perso, the card will switch L0 to L3.

4-3-21. Get firmware version

Host Write:

Len	0xF0
-----	------

Host Read:

Len	0xF0	Status	Data
-----	------	--------	------

Status: 0x00: Operation succeed

Data: firmware version.

4-3-22. Turn on/off Auto-detection

Host Write:

Len	0xFE	Data
-----	------	------

Data: 0x00: Turn off Auto-detection

0x01: Turn on Auto-detection

For example,

02FE00h // Turn off Auto-detection

02FE01h // Turn on Auto-detection

Host Read:

Len	0xFE	Status
-----	------	--------

Status: 0x00: Operation succeed

5. DIFFERENCES FROM PREVIOUS VERSION

Although we make efforts on the compatibility between the new SL030 V3.0 and the old SL030 V1.0-V2.3, there are still some differences you need to know.

1. New SL030 has a new auto-detection function which can close automatically when there is a DESFire or MifarePlus L0/L2/L3 card coming into the detection range, and the light will be on even if the card is out of field. By the way, we also offer you the Turn On/Off Auto-detection command.
2. New SL030 supports nearly all cards of NXP Mifare series now and we rebuilt the card type characters.(Details see to Command Select Mifare Card Description)