

**RFID MODULE**

**Mifare Reader / Writer**

**SL018**

**User Manual**

**Version 1.8**

**Nov 2011**

**StrongLink**

# CONTENT

<b>1. MAIN FEATURES .....</b>	<b>3</b>
<b>2. PINNING INFORMATION .....</b>	<b>4</b>
<b>3. DEVICE OPERATION.....</b>	<b>5</b>
3-1. CLOCK AND DATA TRANSITIONS:.....	5
3-2. START CONDITION .....	5
3-3. STOP CONDITION .....	5
3-4. ACKNOWLEDGE .....	5
3-5. BUSY STATE .....	6
3-6. DEVICE ADDRESSING .....	6
3-7. WRITE OPERATIONS.....	6
3-8. READ OPERATIONS .....	6
<b>4. COMMAND DESCRIPTION.....</b>	<b>7</b>
4-1. FORMAT.....	7
4-2. COMMAND OVERVIEW.....	8
4-3. COMMAND LIST .....	9
4-3-1. Select Mifare card .....	9
4-3-2. Login to a sector .....	9
4-3-3. Read a data block .....	9
4-3-4. Write a data block .....	10
4-3-5. Read a value block .....	10
4-3-6. Initialize a value block .....	10
4-3-7. Write master key (KeyA) .....	11
4-3-8. Increment value .....	11
4-3-9. Decrement value.....	11
4-3-10. Copy value.....	12
4-3-11. Read a data page (UltraLight) .....	12
4-3-12. Write a data Page (UltraLight) .....	12
4-3-13. Control Red Led .....	13
4-3-14. Reset .....	13
4-3-15. Get firmware version.....	13

## 1. MAIN FEATURES



- Tags supported: Mifare 1k, Mifare 4k, Mifare UltraLight
- Auto detecting tag
- Integrated antenna
- 0 to 400 KHz bit-wide I<sup>2</sup>C bus communication
- 4.5 to 7.0 VDC supply voltage
- Operating distance: Up to 60 mm, depending on tag
- Storage temperature: -40 °C ~ +85 °C
- Operating temperature: -20 °C ~ +70 °C
- Dimension: 65 × 45 × 7 mm
- The TagSta pin at low level indicates tag in detective range, and high level indicating tag out

## 2. PINNING INFORMATION

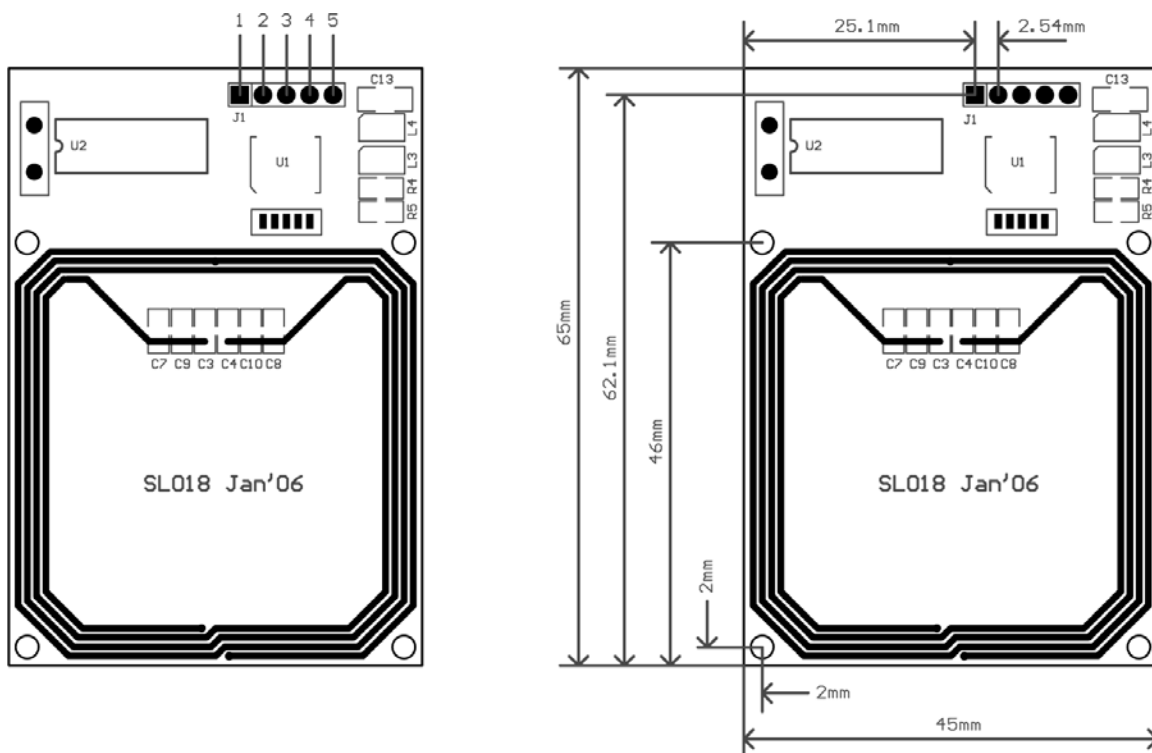

HOLE Dia. = 2.5mm, x 4

PIN	SYMBOL	TYPE	DESCRIPTION
1	TagSta	Output	Tag detect signal low level indicating tag in high level indicating tag out
2	SDA	Input/Output	Serial Data Line
3	SLC	Input	Serial Clock Line
4	VCC	PWR	Power Supply
5	GND	PWR	Ground

### 3. DEVICE OPERATION

#### 3-1. CLOCK AND DATA TRANSITIONS:

The SDA pin is normally pulled high with an external device. Data on the SDA pin may change only during SCL low time periods. Data changes during SCL high periods will indicate a start or stop condition as defined below.

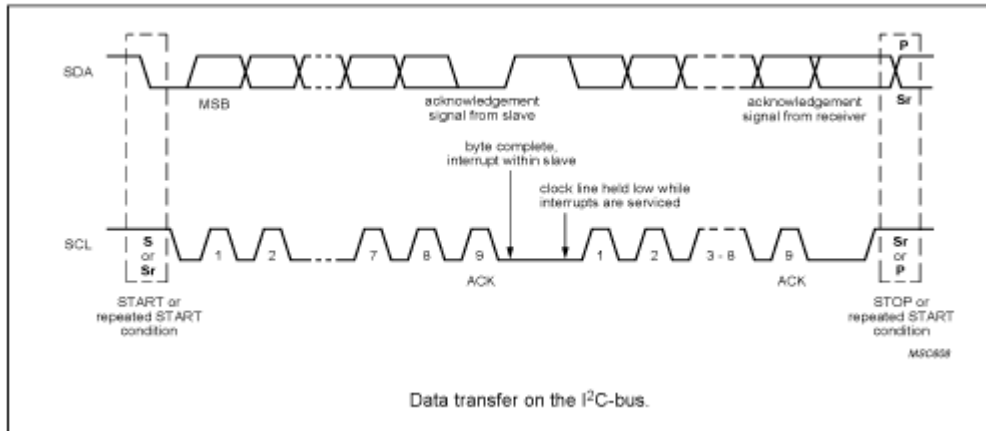

#### 3-2. START CONDITION

A high-to-low transition of SDA with SCL high is a start condition which must precede any other command

#### 3-3. STOP CONDITION

A low-to-high transition of SDA with SCL high is a stop condition.

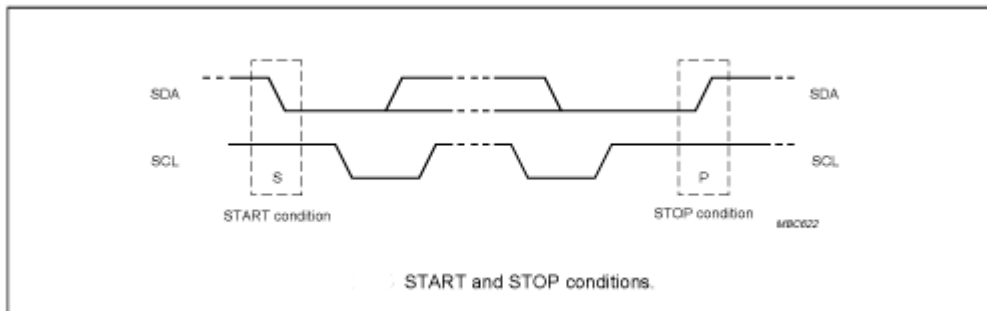

#### 3-4. ACKNOWLEDGE

All addresses and data words are serially transmitted to and from the SL018 in 8-bit words. The SL018 sends a zero to acknowledge that it is not busy, and has received each word. This happens during the ninth clock cycle.

**3-5. BUSY STATE**

When the SL018 has received command, then don't acknowledge IIC bus until ends with the card communication.

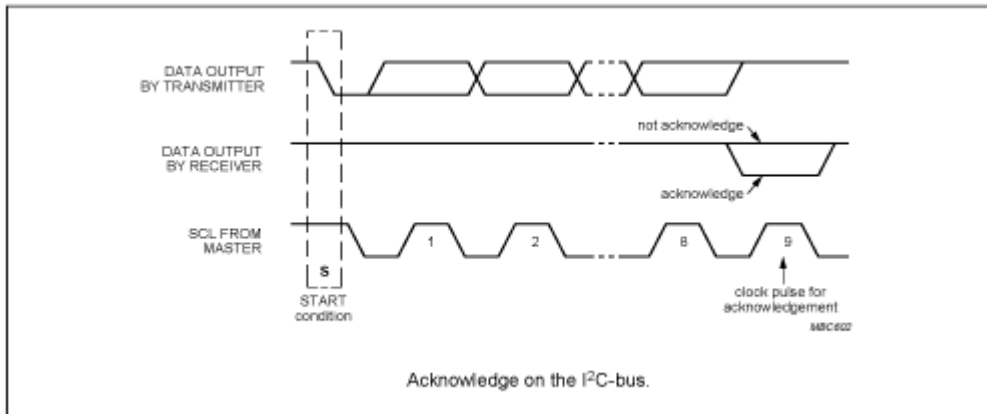

**3-6. DEVICE ADDRESSING**

The SL018 devices require an 8-bit device address word following a start condition to enable the chip for a read or write operation.

The device address word consists of 7 bits addressing and 1 bit operation select bit.

The first 7 bits are the SL018 addressing, is 1010000

The eighth bit of the device address is the read/write operation select bit. A read operation is initiated if this bit is high and a write operation is initiated if this bit is low.



The first byte after the START procedure.

**3-7. WRITE OPERATIONS**

The host device send a command(refer chapter 4) to SL018 via write operation, then SL018 will carry out the order that receive. Finished time according to different order

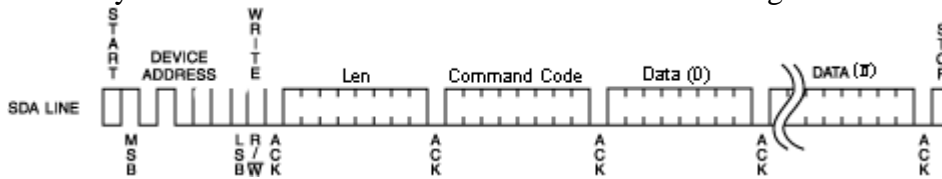

**3-8. READ OPERATIONS**

The host device passes to read the operation gets the order carries out the result

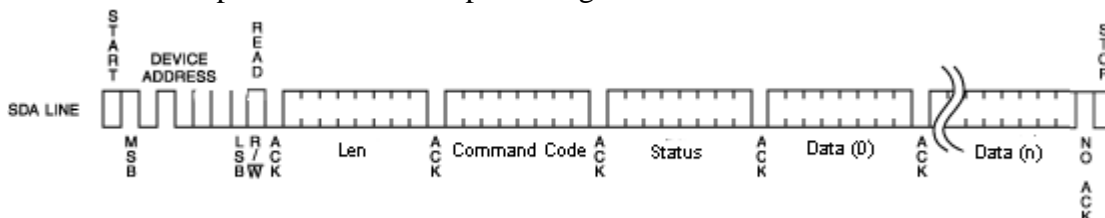

## 4. COMMAND DESCRIPTION

### 4-1. FORMAT

#### Host Write Command to SL018:

Address	Len	Command	Data
---------	-----	---------	------

Address: 1 byte, 0xA0

Len: 1 byte indicating the number of bytes from Command to Checksum

Command: 1 byte Command code, see Table 3

Data: Variable length depends on the command type

#### Host Read The Result:

Address	Len	Command	Status	Data
---------	-----	---------	--------	------

Address: 1 byte, 0xA1

Len: 1 byte indicating the number of bytes from Command to Checksum

Command: 1 byte Command code, see Table 3

Status: 1 byte Command status, see Table 4

Data: Variable length depends on the command type.

**4-2. COMMAND OVERVIEW****Table 3**

<b>Command</b>	<b>Description</b>
0x01	Select Mifare card
0x02	Login to a sector
0x03	Read a data block
0x04	Write a data block
0x05	Read a value block
0x06	Initialize a value block
0x07	Write master key (key A)
0x08	Increment value
0x09	Decrement value
0x0A	Copy value
0x10	Read a data page (ultra_light)
0x11	Write a data page (ultra_light)
0x40	Control the red led
0xF0	Get firmware version
0xFF	Reset

**STATUS OVERVIEW****Table 4**

<b>Status</b>	<b>Description</b>
0x00	Operation succeed
0x01	No tag
0x02	Login succeed
0x03	Login fail
0x04	Read fail
0x05	Write fail
0x06	Unable to read after write
0x0A	Collision occur
0x0C	Load key fail
0x0D	Not authenticate
0x0E	Not a value block

### 4-3. COMMAND LIST

#### 4-3-1. Select Mifare card

##### Host Write:

Len	0x01
-----	------

##### Host Read:

Len	0x01	Status	UID	Type
-----	------	--------	-----	------

Status: 0x00: Operation succeed  
 0x01: No tag  
 0x0A: Collision occur

UID: The uniquely serial number of Mifare card

Type: 0x01: Mifare 1k, 4 byte UID  
 0x02: Mifare 1k, 7 byte UID <sup>[1]</sup>  
 0x03: Mifare UltraLight, 7 byte UID  
 0x04: Mifare 4k, 4 byte UID  
 0x05: Mifare 4k, 7 byte UID <sup>[1]</sup>  
 0x06: Mifare DesFire, 7 byte UID  
 0x0A: Other

#### 4-3-2. Login to a sector

##### Host Write:

Len	0x02	Sector	Type	Key
-----	------	--------	------	-----

Sector: Sector need to login

Type: Key type (0xAA: authenticate with KeyA, 0xBB: authenticate with KeyB)

Key: Authenticate key, 6 bytes

##### Host Read:

Len	0x02	Status
-----	------	--------

Status: 0x02: Login succeed  
 0x01: No tag  
 0x03: Login fail  
 0x0C: Load key fail

#### 4-3-3. Read a data block

##### Host Write:

Len	0x03	Block
-----	------	-------

Block: The block number to be read, 1 byte

##### Host Read:

Len	0x03	Status	Data
-----	------	--------	------

Status: 0x00: Operation succeed  
 0x04: Read fail  
 0x0D: Not authenticate  
 0x01: No tag

Data: Block data returned if operation succeeds, 16 bytes.

**4-3-4. Write a data block****Host Write:**

Len	0x04	Block	Data
-----	------	-------	------

Block: The block number to be written, 1 byte.

Data: The data to write, 16 bytes.

**Host Read:**

Len	0x04	Status	Data
-----	------	--------	------

Status: 0x00: Operation succeed

0x01: No tag

0x05: Write fail

0x06: Unable to read after write

0x07: Read after write error

0x0D: Not authenticate

Data: Block data written if operation succeeds, 16 bytes.

**4-3-5. Read a value block****Host Write:**

Len	0x05	Block
-----	------	-------

Block: The block number to be read, 1 byte.

**Host Read:**

Len	0x05	Status	Value
-----	------	--------	-------

Status: 0x00: Operation succeed

0x01: No tag

0x04: Read fail

0x0D: Not authenticate

0x0E: Not a value block

Value: Value returned if the operation succeeds, 4 bytes.

**4-3-6. Initialize a value block****Host Write:**

Len	0x06	Block	Value
-----	------	-------	-------

Block: The block number to be initialized, 1 byte.

Value: The value to be written, 4 bytes.

**Host Read:**

Len	0x06	Status	Value
-----	------	--------	-------

Status: 0x00: Operation succeed

0x01: No tag

0x05: Write fail

0x06: Unable to read after write

0x07: Read after write error

0x0D: Not authenticate

Value: Value written if the operation succeeds, 4 bytes.

**4-3-7. Write master key (KeyA)****Host Write:**

Len	0x07	Sector	Key
-----	------	--------	-----

Sector: The sector number to be written, 1 byte.

Key: Authentication key, 6 bytes

**Host Read:**

Len	0x07	Status	Key
-----	------	--------	-----

Status: 0x00: Operation succeed

0x01: No tag

0x05: Write fail

0x0D: Not authenticate

Key: Authentication key written if the operation succeeds, 6 bytes.

**4-3-8. Increment value****Host Write:**

Len	0x08	Block	Value
-----	------	-------	-------

Block: The block number to be increased, 1 byte.

Value: The value to be increased by, 4 bytes.

**Host Read:**

Len	0x08	Status	Value
-----	------	--------	-------

Status: 0x00: Operation succeed

0x01: No tag

0x05: Write fail

0x06: Unable to read after write

0x0D: Not authenticate

0x0E: Not a value block

Value: The value after increment if the operation succeeds, 4 bytes

**4-3-9. Decrement value****Host Write:**

Len	0x09	Block	Value
-----	------	-------	-------

Block: The block number to be decreased, 1 byte

Value: The value to be decreased by, 4 bytes

**Host Read:**

Len	0x09	Status	Value
-----	------	--------	-------

Status: 0x00: Operation succeed

0x01: No tag

0x05: Write fail

0x06: Unable to read after write

0x0D: Not authenticate

0x0E: Not a value block

Value: The value after decrement if the operation succeeds, 4 bytes

**4-3-10. Copy value****Host Write:**

Len	0x0A	Source	Destination
-----	------	--------	-------------

Source: The source block copy from, 1 byte

Destination: The destination copy to, 1 byte

The source and destination must in the same sector

**Host Read:**

Len	0x0A	Status	Value
-----	------	--------	-------

Status: 0x00: Operation succeed

0x01: No tag

0x05: Write fail

0x06: Unable to read after write

0x0D: Not authenticate

0x0E: Not a value block (Source)

Value: The value after copy if the operation succeeds, 4 bytes

**4-3-11. Read a data page (UltraLight)****Host Write:**

Len	0x10	Page
-----	------	------

Page: The page number to be read, 1 byte

**Host Read:**

Len	0x10	Status	Data
-----	------	--------	------

Status: 0x00: Operation succeed

0x01: No tag

0x04: Read fail

Data: Block data returned if operation succeeds, 4 bytes.

**4-3-12. Write a data Page (UltraLight)****Host Write:**

Len	0x11	Page	Data
-----	------	------	------

Page: The page number to be written, 1 byte.

Data: The data to write, 4 bytes.

**Host Read:**

Len	0x11	Status	Data
-----	------	--------	------

Status: 0x00: Operation succeed

0x01: No tag

0x05: Write fail

0x06: Unable to read after write

0x07: Read after write error

Data: page data written if operation succeeds, 4 bytes.

**4-3-13. Control Red Led****Host Write:**

Len	0x40	Code
-----	------	------

Code: 0 command red led turn off , other red led turn on, 1 byte

**Host Read:**

Len	0x40	Status
-----	------	--------

Status: 0x00: Operation succeed

**4-3-14. Reset****Host Write:**

Len	0xFF
-----	------

No return

**4-3-15. Get firmware version****Host Write:**

Len	0xF0
-----	------

**Host Read:** <sup>[2]</sup>

Len	0xF0	Status	Data
-----	------	--------	------

Status: 0x00: Operation succeed

Data: firmware version.

**Remark**

<sup>[1]</sup> In order to supports 7 byte UID Mifare class, the firmware of SL018 has been updated to Ver2.2 in Mar 2011.

And older firmware version (such as Ver1.0, 1.6, 2.0, etc) only supports 4 byte UID. Please refer to NXP [Customer Letter UID](#) for detailed information of 4 byte & 7 byte UID of Mifare products.

<sup>[2]</sup> One sample of SL018 response

	Len	Command	Status	Data (Firmware version)
HEX	0B	F0	00	53 4C 30 31 38 2D 32 2E 32
ASCII				“SL018-2.2”